



Description

HB39 is a medium/high-end dustproof clean lamp, suitable for retail and wholesale. A variety of installation methods, lifting ring, hook, hanging pipe optional, and beautiful appearance, light weight, appearance diameter of about 400mm.

Key Features

- Light efficiency: 140lm/w
- Multiple lighting distribution option, dotted lens with better glare control.
- Built-in motion sensor, more compact size
- Various accessories are available
- IP66 & IP69K/IK08 double protection

Applications

- Food Processing Plant
- Warehouse
- Factory
- Pharmaceutical Manufacturing Facilities
- Chemical Facilities
- Beverage Processing
- Poultry and Meat Processing
- Pet-food Production

* Lumen output and light distribution are only for reference. Not all product variations listed on this page are DLC Standard/Premium qualified. Visit /search to confirm qualification.

Electrical Information				
Model No.	HB39-100	HB39-120	HB39-150	HB39-200
Power Consumption(±5%)	100W	120W	150W	200W
Power Supply	SOSEN			
Input Voltage	120-277 / 277-480 VAC 50/60 Hz			120-277 VAC 50/60 Hz
Power Factor	>0.95			
Surge Protection	4kV line-line, 4kV line-earth			
Driver Type	Constant Current (CC)			
Control	Dimmable			
	Microwave Sensor			

Optic Information				
LED Type	Seoul Chip			
Luminous Flux (±10%)	14,000lm	16,800lm	21,000lm	28,000lm
Efficacy(5000K Ra80)	140lm/W			
Correlated Color Temperature	5000K (3000K, 4000K optional)			
Color Rendering Index	Ra80			
Beam Angle	H00129 / H00125 / H00128			
UGR level	<28			

Dimensions and Mount

Product Dimension	φ398×211mm (φ15.66" x 8.3")
Luminaire Net Weight	4.66±0.3kg (10.27±0.66Lbs)
Export Carton Size	450*450*245mm (17.7"x17.7"x 9.7")
Gross Weight	5.9±0.3kg (13±0.66Lbs)
Mounting Option	Loop Hanging
	Hook Mounting, Pipe Mounting
Material	Aluminum Alloy
	Polycarbonate Optical Lens
Finish	Powder Coating
Fixture Color	White
EPA	NA
IK Rating	IK08
IP Rating	IP66 & IP69K
Category of corrosion	C3

Lifespan and Warranty

Operating Temperature	-30°C to + 45°C (-22°F ~ 113°F)
Life Time of LED @Ta=25°C	53,000hrs-L90
	82000hrs-L80
	131000hrs-L70
Warranty	5 Years

New Features

** Please consult us for details.*

Photometry

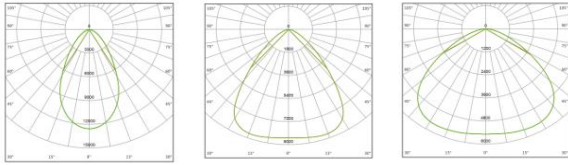

H00129

H00125

H00128

Mounting Options

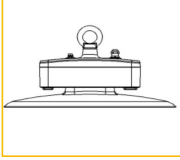

Loop Hanging

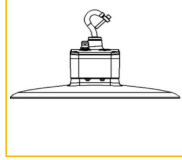

Hook Mounting

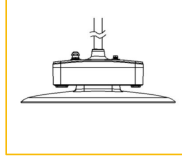

Pipe Mounting

Dimensions

Unit:mm

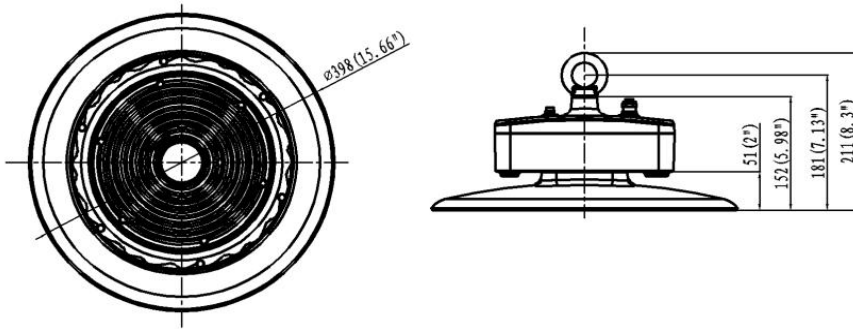

Accessories



Optic lens
High transmittance PC materials, UV test approval.
Code: please refer to **Photometry** for different beam angle.



Aluminium reflectors
Different beam angle, anti glare effect, black/silvery color options.
Code: H00D02 (90°)
Code: H00D04 (110°)
Code: H00D03 (65°)



PC reflector
90° PC reflector with lid.
Code: H00C01A+H00C01B (90°)

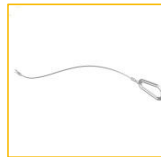

Safety rope
304 stainless steel, available for 0.25m, 1m, 1.5m and 5m long.
Code: SC-H01-01a



Microwave motion sensor
12Vdc input, IP65 rating, max detect height is 15m.



NPT Adaptor
Adaptor for 3/4" NPT pendant mount