

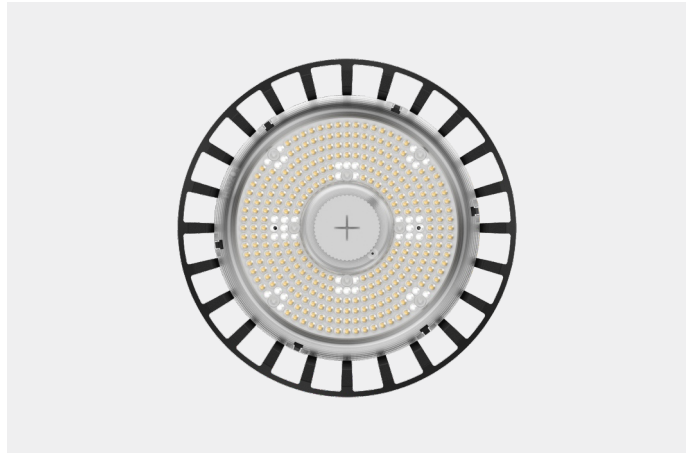

- Up to 150lm/W
- Power selectable
- CCT selectable
- CR180
- Flicker free
- 0-10V
- CASAMBI
- PIR
- Microwave

LED HIGH BAY LIGHT

HB72



Description

The HB72 high bay is an economical model with intelligent control, designed to create a flexible lighting environment for modern industrial and commercial spaces. It offers three power options of 100W, 150W, and 200W, and supports three adjustable power levels. Additionally, it comes in three adaptable sizes to match different energy consumption and space requirements. The fixture also features two installation methods: hook and bracket. Moreover, 2 temperature switching function allows for a seamless transition from 4000K warm light for a cozy atmosphere to 5000K cool light for efficient illumination, effortlessly transforming the ambiance of the space with just one click.

Key Features

- 150lm/W
- 2 CCT and 3 Power selectable
- IP65 and IK08
- No flicker provides stable lighting experience
- Supports 0-10V dimming and sensor

Applications





Suffix	3 Power selectable	2 CCT selectable	0-10V dim	Sensor
WS	✓	-	✓	-
2CS	-	✓	-	-
PIR/Microwave	-	-	-	✓

GENERAL INFORMATION

Housing materials	Aluminum alloy
Housing finish	Powder coating
Optic materials	Polycarbonate
Fixture color	Black(RAL9017)
Electrical class	Class I
CCT selection DIP switch	Yes
Power selection DIP switch	Yes
Emergency	NO
Sensor	Optional
Light source SDCM	<5
Impact resistance	IK08
Ingress protection	IP65
Certification	ETL/DLC 5.1 Pre
Warranty(years)	5



Code	HB72-100WS-2CS	HB72-150WS-2CS	HB72-200WS-2CS
Nominal wattage(W) ±5%	100/80/60W selectable	150/120/90W selectable	200/160/120W selectable
Driver type	Constant current(CC)		
Control	0-10V		
Nominal input voltage(V)	120-277Vac/50Hz		
Power factor(at full load)	>0.97		
Flicker factor	SVM<0.4; PST<1		
THD	< 20%		
Surge protection	6KV L-N, 6KV L/N-E		
Light source	LED2835		
Color rendering index	Ra80		
General luminous efficacy(lm/W)	150lm/W		
Color temperature(K)	2-CCT: 4000K+5000K		
Luminous flux(lm) ±10% Ra80	100W: 14400-15300 60W: 8880-9420	150W: 21450-22800 90W: 14580-13770	200W: 28400-30000 120W: 17760-18840
Beam angle	H16801/H16802	H21401/H21402	H27901/H27902
UGR	<28 (H16802/H21402/27902)		
Operating temperature(°C/°F)	-30 to +50 (-22 to +122)		
Lifespan of LED@Ta=25°C(hrs)	163,800-L70B50		
	102,800-L80B50		
	49,800-L90B50		

RECOMMENDED

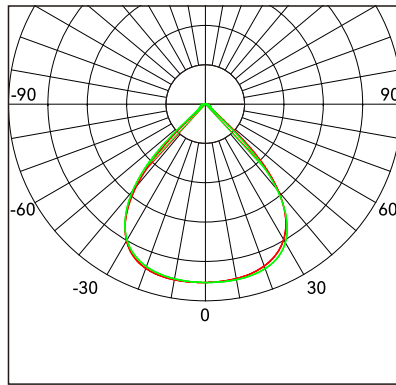
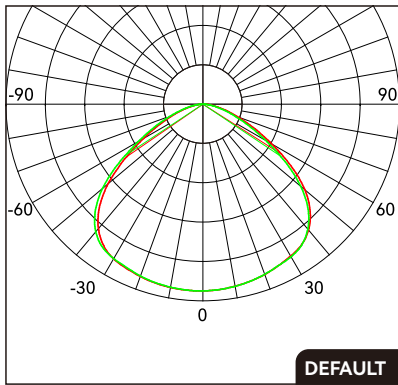

100W	Symmetrical 110° H16801
150W	Symmetrical 110° H21401
200W	Symmetrical 110° H27901

100W	Symmetrical 85° H16802
150W	Symmetrical 85° H21402
200W	Symmetrical 85° H27902

MEASUREMENT

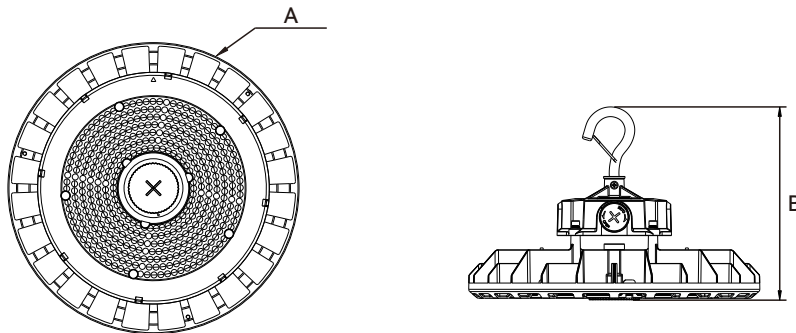

Product code	Luminaire dimensions AxB(mm/inch)	Product weight(kg/lbs) ±6%		Carton size (mm/inch)	Qty/ CTN
		N.W/PC	G.W/CTN		
HB72-100	Ø248x188 (Ø9.76"x7.4")	1.56(3.44)	1.88(4.14)	255x255x145 (10.03"x10.03"x5.71")	1
HB72-150	Ø266x194 (Ø10.47"x7.64")	1.70(3.75)	2.06(4.54)	275x275x150 (10.83"x10.83"x5.91")	1
HB72-200	Ø300x199 (Ø11.81"x7.83")	2.09(4.61)	2.52(5.56)	305x305x155 (12.01"x12.01"x6.10")	1



ACCESSORIES

PC reflector with lid (100W/150W)



Code	Product weight(kg/lbs) ±6%		Package weight(kg/lbs) ±6%		Carton size (mm/inch)	Qty/CTN
	N.W/PC	G.W/PC	N.W/CTN	G.W/CTN		
H00C73A+ H00C01B	1.04(2.29)	-	5.2(11.46)	7.33(16.16)	445x445x315 (17.52"x17.52"x12.4")	5

PC reflector (100W/150W)



Code	Product weight(kg/lbs) ±6%		Package weight(kg/lbs) ±6%		Carton size (mm/inch)	Qty/CTN
	N.W/PC	G.W/PC	N.W/CTN	G.W/CTN		
H00C73A	0.68(1.5)	-	4.08(8.99)	6.17(13.6)	445x445x315 (17.52"x17.52"x12.4")	6

PC reflector with lid (200W)



Code	Product weight(kg/lbs) ±6%		Package weight(kg/lbs) ±6%		Carton size (mm/inch)	Qty/CTN
	N.W/PC	G.W/PC	N.W/CTN	G.W/CTN		

PC reflector (200W)



Code	Product weight(kg/lbs) ±6%		Package weight(kg/lbs) ±6%		Carton size (mm/inch)	Qty/CTN
	N.W/PC	G.W/PC	N.W/CTN	G.W/CTN		
H00C01A	0.65(1.43)	-	3.25(7.17)	5.15(11.35)	480x480x480 (18.9"x18.9"x18.9")	5

ALU reflector (100W/150W)



Code	Product weight(kg/lbs) ±6%		Package weight(kg/lbs) ±6%		Carton size (mm/inch)	Qty/CTN
	N.W/PC	G.W/PC	N.W/CTN	G.W/CTN		
H00D05-01	0.24(0.53)	-	2.4(5.29)	4.15(9.15)	370x370x165 (14.57"x14.57"x6.5")	10

ALU reflector (200W)



Code	Product weight(kg/lbs) ±6%		Package weight(kg/lbs) ±6%		Carton size (mm/inch)	Qty/CTN
	N.W/PC	G.W/PC	N.W/CTN	G.W/CTN		
H00D02	0.22(0.49)	-	2.20(4.85)	3.37(7.43)	452x452x205 (17.8"x17.8"x8.07")	10

Safety chain



Code	Product weight(kg/lbs) ±6%		Package weight(kg/lbs) ±6%		Carton size (mm/inch)	Qty/CTN
	N.W/PC	G.W/PC	N.W/CTN	G.W/CTN		
SC-H54-01	0.11(0.24)	-	5.50(12.13)	5.89(12.99)	320x210x140 (12.6"x18.27"x5.51")	50

Microwave motion sensor



Code	Product weight(kg/lbs) ±6%		Package weight(kg/lbs) ±6%		Carton size (mm/inch)	Qty/CTN
	N.W/PC	G.W/PC	N.W/CTN	G.W/CTN		

Microwave motion sensor



Code	Product weight(kg/lbs) ±6%		Package weight(kg/lbs) ±6%		Carton size (mm/inch)	Qty/CTN
	N.W/PC	G.W/PC	N.W/CTN	G.W/CTN		
SR-H30-02	0.02(0.04)	0.03(0.07)	0.6(1.32)	0.89(1.96)	360x150x155 (14.17"x5.91"x6.1")	20

PIR sensor



Code	Product weight(kg/lbs) ±6%		Package weight(kg/lbs) ±6%		Carton size (mm/inch)	Qty/CTN
	N.W/PC	G.W/PC	N.W/CTN	G.W/CTN		
HN074-01VRPH	0.03(0.07)	0.04(0.09)	4.8(10.58)	5.36(11.82)	400x300x235 (15.75"x11.81"x9.25")	120

PIR sensor



Code	Product weight(kg/lbs) ±6%		Package weight(kg/lbs) ±6%		Carton size (mm/inch)	Qty/CTN
	N.W/PC	G.W/PC	N.W/CTN	G.W/CTN		
SR-H30-03	0.03(0.07)	0.04(0.09)	0.8(1.67)	1.09(2.40)	360x150x155 (14.17"x5.91"x6.1")	20

CASAMBI ready wireless module



Code	Product weight(kg/lbs) ±6%		Package weight(kg/lbs) ±6%		Carton size (mm/inch)	Qty/CTN
	N.W/PC	G.W/PC	N.W/CTN	G.W/CTN		
UP-CN01	0.02(0.04)	0.03(0.07)	0.6(1.32)	0.89(1.96)	360x150x155 (14.17"x5.91"x6.1")	20

Remote Controller for SR-H30-01/HN074-01VRPH



Code	Product weight(kg/lbs) ±6%		Package weight(kg/lbs) ±6%		Carton size (mm/inch)	Qty/CTN
	N.W/PC	G.W/PC	N.W/CTN	G.W/CTN		

Remote Controller for SR-H30-02/SR-H30-03



Code	Product weight(kg/lbs) ±6%		Package weight(kg/lbs) ±6%		Carton size (mm/inch)	Qty/CTN
	N.W/PC	G.W/PC	N.W/CTN	G.W/CTN		
MH10	0.18(0.40)	0.20(0.44)	-	-	-	-

Ceiling bracket



Code	Product weight(kg/lbs) ±6%		Package weight(kg/lbs) ±6%		Carton size (mm/inch)	Qty/CTN
	N.W/PC	G.W/PC	N.W/CTN	G.W/CTN		
BC-H71-01	0.18(0.40)	0.19(0.42)	1.9(4.19)	2.3(5.07)	425x240x190 (16.73"x9.45"x7.48")	10

POWER & CCT SELECTABLE

Factory set: 100% brightness, CW: 5000K

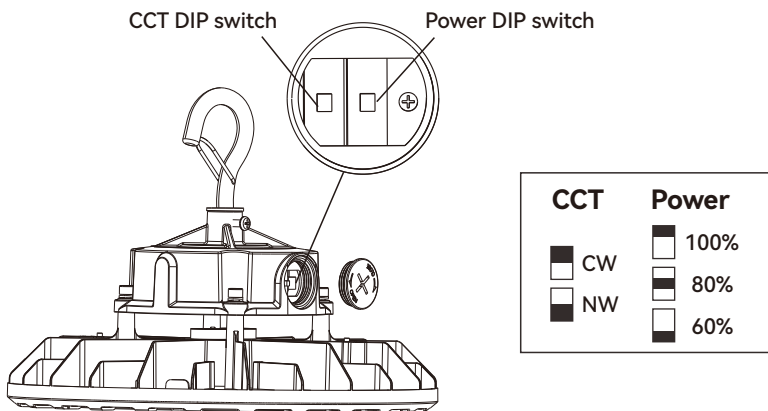

Power Selectable

Power Percentage	200W	150W	100W
100%	200W	150W	100W
80%	160W	120W	80W
60%	120W	90W	60W

* The tolerance for power is ±10%

CCT Selectable

CW: 5000K NW: 4000K



LIGHT YOUR WAY